

*Ceramic Oxide Fabricators*  
**(AUST) PTY LTD**



# Oxygen Sensor C500

Revision 1.0, December 2018

**Ceramic Oxide Fabricators (AUST) Pty Ltd**  
83 Wood Street, California Gully VIC 3556 Australia

## Contents

|           |   |           |
|-----------|---|-----------|
| <b>1</b>  | <b>Revision History</b>   | <b>3</b>  |
| <b>2</b>  | <b>Description</b>  | <b>4</b>  |
| <b>3</b>  | <b>Specifications</b>   | <b>5</b>  |
| <b>4</b>  | <b>General Measurement Setup</b>  | <b>6</b>  |
| 4.1       | General Setup   | 6         |
| <b>5</b>  | <b>Thermocouple interface</b>   | <b>7</b>  |
| <b>6</b>  | <b>Thermocouple ranges</b>  | <b>8</b>  |
| <b>7</b>  | <b>Sensor Interface</b>   | <b>8</b>  |
| <b>8</b>  | <b>Theory of operation</b>  | <b>9</b>  |
| <b>9</b>  | <b>Example calculations and error propagation</b>                             | <b>10</b> |
| 9.1       | Calculating voltage (for calibrated gases)                                    | 10        |
| 9.2       | Calculating oxygen concentration (for measured EMF readings)                  | 10        |
| 9.3       | Error propagation rules   | 11        |
| 9.4       | A table of typical emf readings for various inert gases                       | 11        |
| 9.5       | Consideration of sensor impedance   | 12        |
| 9.6       | Example of measurement error  | 13        |
| 9.7       | Response time with respect to gas changes                                     | 14        |
| 9.8       | Reducing measurement noise  | 14        |
| 9.9       | Lambda Point for control  | 15        |
| <b>10</b> | <b>Ordering information</b>   | <b>16</b> |
| <b>11</b> | <b>Contact information</b>  | <b>16</b> |
| <b>12</b> | <b>Ceramic Oxide Fabricators (AUST) Pty Ltd one (1) year limited warranty</b> | <b>17</b> |
| 12.1      | Introduction  | 17        |
| 12.2      | Specific Warranty obligations   | 17        |
| 12.3      | Warranty exclusions and limitations   | 17        |
| 12.4      | Important!  | 18        |
| 12.5      | Obtaining Warranty Service  | 19        |

## 1 Revision History

### Changes to revision 1.0

- Initial release - first draft 8 March 2017
- Peter Crowhurst updated C500 operating temperature 20 June 2018
- Adam Rady updated C500 electrical specifications 14 December 2018
- Correction to K or N-type thermocouple operating range 26 April 2019

# C500 Sensor

## 2 Description

The C500 sensor is a simple, all ceramic oxygen sensor. It is used for measurement and control of oxygen sensitive environments at high temperatures. The sensor can operate *in* or *ex situ*, and measures oxygen concentration in real time.



### Features

- Specific for O<sub>2</sub>
- High O<sub>2</sub> sensitivity and selectivity
- High dynamic range of detection
- High temperature of operation
- Rapid responses
- *In situ* or *ex situ* measurement
- Solid state electronic component – rugged sensor
- No power consumed for operation under all conditions
- No bias required to operate
- Available up to 1400 mm

### Applications

- Use in heated probe for gas sampling analysis
- Small electric kilns
- Flue gas analysis

### 3 Specifications

| Thermal                   |                   |         |         |                              |
|---------------------------|-------------------|---------|---------|------------------------------|
| Parameter                 | Minimum           | Typical | Maximum | Unit                         |
| Operating temperature†    | 500               | 500-800 | 1600    | °C                           |
| Ramp rate                 | —                 | —       | 600     | °C/hour                      |
| Storage                   | 5                 | —       | 50      | °C                           |
| Electrical                |                   |         |         |                              |
| Parameter                 | Minimum           | Typical | Maximum | Unit                         |
| Output voltage range      | —                 | —       | 1200††  | mV @ $T \geq 500$ °C         |
| Output impedance          | ~20               | 50      | 100     | k $\Omega$ @ $T \geq 500$ °C |
| Response time (10-90%)*   | —                 | 2       | 10      | s @ $T \geq 500$ °C          |
| Offset Error @ 500°C **   | —                 | ±2      | ±5      | mV @ $pO_2 = pO_2'$          |
| Measurement Range         |                   |         |         |                              |
| Parameter                 | Minimum           | Typical | Maximum | Unit                         |
| O <sub>2</sub> Atmosphere | 10 <sup>-24</sup> | —       | 1       | $pO_2$ @ 500 °C              |
| O <sub>2</sub> Atmosphere | 10 <sup>-12</sup> | —       | 1       | $pO_2$ @ 1300 °C             |
| Reference air             | 10                | 40      | 100     | mL/min                       |
| Sensor Mechanical         |                   |         |         |                              |
| Parameter                 | Minimum           | Typical | Maximum | Unit                         |
| Outer Diameter            | 7.85              | 8.00    | 8.15    | mm                           |
| Inner Diameter            | 4.90              | 5.05    | 5.20    | mm                           |
| Cut length                | 300               | —       | 1400    | mm ±3 mm                     |
| Weight                    | —                 | 11.1    | —       | g/100 mm                     |

† Continuous use of sensor above 1300 °C reduces the lifetime of the sensor.

†† Under heavily reducing conditions, an output voltage of greater than 1200 mV may be observed. Readings above 1400 mV or greater than 1600 degrees may result in erroneous readings. Absolute maximum output voltage without damage to the sensor for the given atmosphere of 10<sup>-24</sup> oxygen concentration. The sensor will provide an output response above 1130 mV, however lifetime cannot be guaranteed under these operating conditions.

\* Response times given here are applicable to most reducing atmospheres. Response times will vary depending on test gas type and may be slower for inert atmospheres.

\*\* Offset error should be subtracted from the voltage reading during measurements for high accuracy applications. Also, note that this offset value is temperature dependent and that short hot zones/large thermal gradients across the sensor will contribute to higher offset errors.

The sensor within a probe can be installed anywhere in the kiln or furnace if used at temperatures below 1100°C. For operating temperatures above 1100°C, the probe should hang vertically, to avoid sag and loss of internal electrical contact.

## 4 General Measurement Setup

Key to accurate measurements of the oxygen concentration of the gaseous environments is the measurement setup, namely:

1. Probe location;
2. Electrical interface;
3. Measurement instrumentation;
4. Reference air and air flow rate.

### 4.1 General Setup



Ideal electrical interface to the probe will have the following characteristics, and include a diaphragm air pump to supply the clean reference air.

| Oxygen Sensor Measurement Instrument |            |           |
|--------------------------------------|------------|-----------|
| Parameter                            | Typical    | Unit      |
| Ideal input impedance                | 1          | $T\Omega$ |
| Input voltage range                  | $\pm 2000$ | mV        |
| Filter                               | 50 – 60    | Hz        |
| Thermocouple Measurement Instrument  |            |           |
| Parameter                            | Typical    | Unit      |
| Ideal input impedance                | 10         | $M\Omega$ |
| Input voltage range                  | $\pm 100$  | mV        |
| Filter                               | 50 – 60    | Hz        |

## 5 Thermocouple interface

Connecting the thermocouple to instrumentation must be done with consideration to optimize accuracy and, ensure unwanted noise does not appear in the measurement process. The resultant temperature measurement is only as accurate as the sensor and its interface.

The thermocouple produces a small thermo-electric electromotive force (emf), typically  $40\mu\text{V}/^\circ\text{C}$  and it is necessary to minimize spurious thermal emf signals and ohmic effects which would otherwise result in incorrect readings.

The length of cable used between the sensor and the instrument is an important consideration because the line resistance has to be taken into account (although the instrument input is effectively high impedance, typically  $1\text{ M}\Omega - 10\text{ M}\Omega$ ). Most instruments specify a maximum of  $100\ \Omega$  loop cable resistance without accuracy being compromised.

With long cable runs, the cable may need to be screened and earthed at one end (at the instrument) to minimize noise pick-up (interference) on the measuring circuit.

An extension cable uses true thermocouple wire and is designated X (e.g. KX for type K); compensation cable has a C designation (e.g. KC for VX, type K) and consists of VX and U types. An extension cable should be selected for its temperature and electromotive force relationship to an appropriate standard over the complete temperature range, for the thermocouple used. This cable can then be used for joining thermocouples to their measuring instruments.

Compensating cable, which uses lower cost alloys, has a different composition to an extension cable but still having a similar temperature versus electromotive force relationship, but only over a limited environmental temperature range. Therefore, compensating cables should only be used for short distances to connect thermocouples to their measuring instruments. Due to these differences in electromotive force generated for temperatures in contrast to thermocouple voltages, these cables cannot be used at temperatures above ambient. This means that care must be taken to ensure the entire electrical connection from the probe to the measurement device is at ambient. For example, the temperature at the probe head connector can be higher than ambient, and so this will cause a voltage to be generated in the compensating cable that can influence the overall voltage measured by the instrumentation, and so result in an error in actual temperature reading.

Direct connection is made using an appropriate type of cable; this is indicated by colour coding according to IEC 584-3 on the insulation. Correct polarity and a mechanically sound connection is vital.

Compensation and extension cables should be used for all measurements with thermocouples. The reference air and compensation or extension cables are available on request, and are quoted for separately. Standard shielded signal cable can be used for interfacing the oxygen sensor to the measurement instruments. For best performance, the measurement made should be using differential inputs to the instrument to remove unwanted common mode noise.

Australian Oxytrol Systems supplies interface cable that supports the following connections:

- (i) R or K type compensation cable
- (ii) Electrical interface for  $\text{O}_2$  sensor
- (iii) Reference air

## 6 Thermocouple ranges

| Type†  | Temperature Range |              | Tolerances-Reference |        |                    |        |
|--------|-------------------|--------------|----------------------|--------|--------------------|--------|
|        | °C                | °F           | Standard Tolerances  |        | Special Tolerances |        |
|        | °C                | °F           | °C                   | °F     | °C                 | °F     |
| T      | 0 to 370          | 32 to 700    | ± 1.0 or ± 0.75 %    | Note 1 | ± 0.5 or 0.4 %     | Note 1 |
| J      | 0 to 760          | 32 to 1400   | ± 2.2 or ± 0.75 %    |        | ± 1.1 or 0.4 %     |        |
| E      | 0 to 870          | 32 to 1600   | ± 1.7 or ± 0.5 %     |        | ± 1.0 or 0.4 %     |        |
| K or N | 0 to 1260         | 32 to 2300   | ± 2.2 or ± 0.75 %    |        | ± 1.1 or 0.4 %     |        |
| R or S | 0 to 1480         | 32 to 2700   | ± 1.5 or ± 0.25 %    |        | ± 0.6 or ± 0.1 %   |        |
| B      | 870 to 1700       | 1600 to 3100 | ± 0.5 %              |        | ± 0.25 %           |        |
| C      | 0 to 2315         | 32 to 4200   | ± 4.4 or ± 1 %       |        |                    |        |
| T      | -200 to 0         | -328 to 32   | ± 1.0 or ± 1.5 %     |        | ††                 |        |
| E      | -200 to 0         | -328 to 32   | ± 1.7 or ± 1 %       |        | ††                 |        |
| K      | -200 to 0         | -328 to 32   | ± 2.2 or ± 2 %       |        | ††                 |        |

† K and R type thermocouples are standard options for probes.

†† Special tolerances for temperatures below 0°C are difficult to justify, values for Type E and T thermocouples are suggested as a guide.

Type E (-200 to 0) °C ± 1 °C or ± 0.5 %, whichever is greater

Type T (-200 to 0) °C ± 0.5°C or ± 0.8 %, whichever is greater

Note 1: The Fahrenheit tolerance is 1.8 times larger than the °C tolerance at the equivalent °C temperature. Note particularly that percentage tolerance applies only to temperatures expressed in °C.

## 7 Sensor Interface

The instrument interfacing to the sensor should support positive and negative voltage polarities, with the measurement instrument having a high input impedance, typically TΩ. For best performance, the measurement made should be using differential inputs to the instrument to remove unwanted common mode noise.



## 8 Theory of operation

The zirconia-based pellet in the sensor is an oxygen ion conducting solid electrolyte. When the sensor is exposed to different partial pressures of oxygen, across the internal and external faces, an electromotive force is produced. The generated electromotive force follows the Nernst equation:

$$E = \frac{RT}{4F} \ln \left( \frac{pO_2}{pO'_2} \right)$$

- $E$  is the electromotive force as a voltage (V);
- $T$  is the temperature in degrees Kelvin;
- $pO'_2$  partial pressure of oxygen in reference air (inside sensor);
- $pO_2$  partial pressure of oxygen in test gas (outside sensor);
- $F$  Faraday's constant  $96485 \text{ C mol}^{-1}$ ;
- $R$  Gas constant  $8.3145 \text{ JK}^{-1}\text{mol}^{-1}$ .

The reference partial pressure of gas is 20.9 %, making  $pO'_2=0.209$ . Note, COF's convention is for reducing atmospheres ( $pO_2 < 0.209$ ) to result in a negative  $E$  value. Rearranging for the partial pressure of oxygen external to the reference partial pressure of oxygen:

$$pO_2 = pO'_2 e^{\frac{4FE}{RT}}$$

The source impedance of the sensor is subject to the temperature of operation, and varies subject to gas conditions, temperature and reference air. The sensor impedance varies, presenting as an open circuit when cold;  $M\Omega$  at low temperatures;  $k\Omega$  at operating temperatures of 700 °C and above. The operating impedance has a range subject to manufacturing tolerances.

## 9 Example calculations and error propagation

### 9.1 Calculating voltage (for calibrated gases)

Using the Nernst equation to calculate sensor output voltage with respect to known oxygen concentration.

$$E = \frac{RT}{4F} \ln \left( \frac{pO_2}{pO'_2} \right)$$

- $E$  is the electromotive force as a voltage (V);
- $T$  is the temperature in degrees Kelvin;
- $pO_2$  partial pressure of oxygen outside;
- $pO'_2$  partial pressure of oxygen inside;
- $F$  Faraday's constant  $96485 \text{ C mol}^{-1}$ ;
- $R$  Gas constant  $8.3145 \text{ JK}^{-1}\text{mol}^{-1}$ .

Using the following values:

1. Kiln temperature measured by the probe is  $700^\circ\text{C}$ ;
2. Partial pressure of  $O_2$  in reference air of 0.2095 (or 20.95%)<sup>†</sup>;
3. Measurement air to have 1 % oxygen concentration (partial pressure of 0.01);
4.  $E$  is the unknown component.

<sup>†</sup> Since the partial pressure of reference air (oxygen inside) and measurement air (oxygen outside) concentrations are taken as a ratio, this ratio becomes dimensionless.

$$E = \frac{RT}{4F} \ln \left( \frac{pO_2}{pO'_2} \right)$$

The above can now be written as follows:

$$E = \frac{8.3145 \text{ JK}^{-1}\text{mol}^{-1} (700^\circ\text{C} + 273.15)}{4.96485 \text{ Cmol}^{-1}} \ln \left( \frac{0.01}{0.2095} \right)$$

$$E = -0.063768 \text{ V} \text{ or } E = -63.768 \text{ mV}$$

### 9.2 Calculating oxygen concentration (for measured EMF readings)

Rearranging the Nernst equation to calculate oxygen concentration from the sensor output, as a measured millivolt reading.

$$pO_2 = pO'_2 \cdot e^{\frac{E \cdot 4F}{RT}}$$

Using the following known values:

1. Kiln temperature measured by the probe is  $700^\circ\text{C}$ ;
2. Partial pressure of  $O_2$  in reference air of 0.2095 (or 20.95%)<sup>†</sup>;
3.  $E$  is the known component,  $E = -0.063768 \text{ V}$  (as measured);
4.  $pO_2$  is the unknown component.

$$= 0.2095 \cdot e^{\frac{-0.063768 \cdot 4 \cdot 96485 \text{ Cmol}^{-1}}{8.3145 \text{ JK}^{-1}\text{mol}^{-1} \cdot (700^\circ\text{C} + 273.15)}}$$

$$pO_2 = 0.01 \text{ or } 1\% \text{ concentration}$$

### 9.3 Error propagation rules

The following error propagation rules may be applied to the calculations to obtain uncertainties.

$$f = A \cdot B \quad \sigma_f^2 \approx f^2 \cdot \left[ \left( \frac{\sigma_A}{A} \right)^2 + \left( \frac{\sigma_B}{B} \right)^2 + 2 \frac{\sigma_{AB}}{AB} \right]$$

$$f = \frac{A}{B} \quad \sigma_f^2 \approx f^2 \cdot \left[ \left( \frac{\sigma_A}{A} \right)^2 + \left( \frac{\sigma_B}{B} \right)^2 - 2 \frac{\sigma_{AB}}{AB} \right]$$

$$f = aA^b \quad \sigma_f^2 \approx \left( \frac{fb\sigma_A}{A} \right)^2$$

$$f = a \ln(bA) \quad \sigma_f^2 \approx \left( a \frac{\sigma_A}{A} \right)^2$$

### 9.4 A table of typical emf readings for various inert gases

| Molar/Volume % O <sub>2</sub> in Inert Gas (eg Nitrogen). EMF values are negative mV |                                     |                                     |                           |                   |                    |
|--|-------------------------------------|-------------------------------------|---------------------------|-------------------|--------------------|
| Temperature  | 1% O <sub>2</sub> in N <sub>2</sub> | 5% O <sub>2</sub> in N <sub>2</sub> | Industrial N <sub>2</sub> | HP N <sub>2</sub> | UHP N <sub>2</sub> |
| °C / (F)   | 1% ± 0.02%                          | 5% ± 0.08%                          | 10ppm ± 1ppm              | 2ppm ± 0.1ppm     | 0.1ppm ± 0.05ppm   |
| 600 / (1112)   | 56.80 - 57.56                       | 26.60 - 27.21                       | 185.31 - 189.09           | 216.46 - 218.35   | 266.10 - 286.77    |
| 650 / (1202)   | 60.06 - 60.85                       | 28.13 - 28.76                       | 195.93 - 199.92           | 228.86 - 230.85   | 281.34 - 303.19    |
| 700 / (1292)   | 63.31 - 64.15                       | 29.65 - 30.32                       | 206.54 - 210.75           | 241.25 - 243.35   | 296.58 - 319.61    |
| 750 / (1382)   | 66.56 - 67.44                       | 31.18 - 31.88                       | 217.15 - 221.57           | 253.65 - 255.86   | 311.82 - 336.03    |
| 800 / (1472)   | 69.81 - 70.74                       | 32.70 - 33.44                       | 227.76 - 232.40           | 266.04 - 268.36   | 327.05 - 352.45    |
| 850 / (1562)   | 73.07 - 74.04                       | 34.22 - 35.00                       | 238.37 - 243.23           | 278.44 - 280.86   | 342.29 - 368.87    |
| 900 / (1652)   | 76.32 - 73.33                       | 35.75 - 36.55                       | 248.99 - 254.06           | 290.84 - 293.37   | 357.53 - 385.29    |
| 950 / (1740)   | 79.57 - 80.63                       | 37.27 - 38.11                       | 259.60 - 264.89           | 303.23 - 305.87   | 372.77 - 401.72    |
| 1000 / (1832)  | 82.83 - 83.92                       | 38.79 - 39.67                       | 270.21 - 275.71           | 315.63 - 318.37   | 388.01 - 418.14    |
| 1050 / (1922)  | 86.08 - 87.22                       | 40.32 - 41.23                       | 280.82 - 286.54           | 328.02 - 330.88   | 403.24 - 434.56    |
| 1100 / (2012)  | 89.33 - 90.52                       | 41.84 - 42.79                       | 291.43 - 297.37           | 340.42 - 343.38   | 418.48 - 450.98    |
| 1150 / (2102)  | 92.58 - 93.81                       | 43.36 - 44.34                       | 302.05 - 308.20           | 352.81 - 355.88   | 433.72 - 467.40    |
| 1200 / (2192)  | 95.84 - 97.11                       | 44.89 - 45.90                       | 312.66 - 319.03           | 365.21 - 368.38   | 448.96 - 483.82    |
| 1250 / (2282)  | 99.09 - 100.40                      | 46.41 - 47.46                       | 323.27 - 329.85           | 377.60 - 380.89   | 464.20 - 500.24    |
| 1300 / (2372)  | 102.34 - 103.70                     | 47.93 - 49.02                       | 333.88 - 340.68           | 390.00 - 393.39   | 479.43 - 516.67    |
| 1350 / (2462)  | 105.60 - 106.99                     | 49.46 - 50.58                       | 344.49 - 351.51           | 402.40 - 405.89   | 494.67 - 533.09    |
| 1400 / (2552)  | 108.85 - 110.29                     | 50.98 - 52.13                       | 355.10 - 362.34           | 414.79 - 418.40   | 509.91 - 549.51    |
| 1450 / (2642)  | 112.10 - 113.59                     | 52.50 - 53.69                       | 365.72 - 373.17           | 427.19 - 430.90   | 525.15 - 565.93    |
| 1500 / (2732)  | 115.35 - 116.88                     | 54.03 - 55.25                       | 376.33 - 383.99           | 439.58 - 443.40   | 540.39 - 582.35    |
| 1550 / (2822)  | 118.61 - 120.18                     | 55.55 - 56.81                       | 386.94 - 394.82           | 451.98 - 455.91   | 555.63 - 598.77    |
| 1600 / (2912)  | 121.87 - 123.47                     | 57.07 - 58.37                       | 397.55 - 405.65           | 464.37 - 468.41   | 570.86 - 615.19    |

#### Notes

- Please note that other impurities such as CO, CO<sub>2</sub>, H<sub>2</sub>, H<sub>2</sub>O, CH<sub>4</sub>, etc. may also have an effect on the emf
- Values given are a guide only and dependent on gas suppliers, please refer to your own certificate of analysis for O<sub>2</sub> impurity content and uncertainties
- HP is High Purity
- UHP is Ultra-High Purity

## 9.5 Consideration of sensor impedance

Sensor conductance has an Arrhenius relationship with temperature. Impedance as a function of temperature is an important consideration from the following perspectives:

1. Measurement equipment input impedance;
2. Response time of sensor to gas changes;
3. Electrical noise as observed by the measurement system.

Sensor impedance is an important consideration when interfacing to measurement equipment. The lower the temperature the more influence the measuring equipment input impedance has on the measured signal. Namely, if the input impedance of the measurement equipment is not sufficiently high, errors in signal measurement may fall into unacceptable bounds with respect to measurement uncertainties. In short, the input impedance of the measurement equipment should not load the measured signal.

## 9.6 Example of measurement error

Using the following values:

- Kiln temperature measured by the probe is 350 °C;
- Partial pressure of reference air 0.2095;
- Reference gas that has a 1 % oxygen concentration ( $pO_2 = 0.01$ );
- E is the unknown component.

Using the Nernst equation, we calculate a sensor output voltage of  $E = -40.830$  mV. The impedance derived from both the plot above and the interpolation, yields a signal source impedance of  $1.2$  M $\Omega$ .

Using an instrument with an input impedance of  $1$  M $\Omega$ , the actual measured voltage is calculated as follows, using the known components:

- Kiln temperature measured by the probe is 350 °C;
- Sensor voltage output should be,  $V = -40.830$  mV;
- Impedance of sensor at 350 °C is  $R_S = 1.2$  M $\Omega$ ;
- Instrument input impedance  $R_M = 1.0$  M $\Omega$ ;  $V_M$  is the voltage measured.

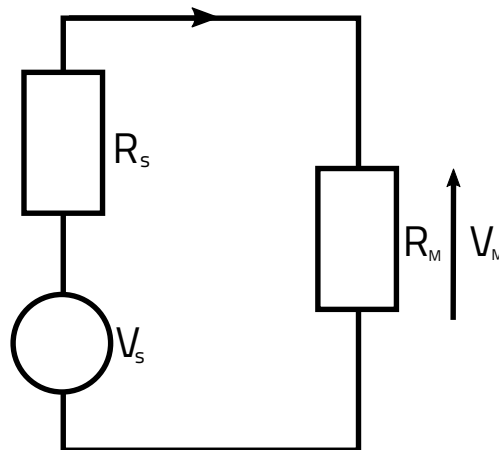

Calculating the system current to be defined as  $i = \frac{V_s}{(R_s + R_M)}$ , the voltage seen by the measurement equipment will then be  $V_M = i \cdot R_M$ . In this instance the measurement voltage will be  $-19.3$  mV, approximately half the sensor unloaded voltage.

The oxygen concentration based upon the erroneous voltage reading will be 5.257%, and not the 1% as was the case in the earlier calculation.

To ensure that voltage measurements are within 1% of the actual voltage to be measured, the instrument input impedance required can be calculated as follows:

- Sensor voltage output should be  $V = -40.380$  mV;
- 1% error on voltage to be measured,  $V_\epsilon = -0.4038$  mV;
- Impedance of sensor at 350 °C is  $R_S = 1.2$  M $\Omega$ ;
- Unknown required instrument impedance;

The voltage drop across the sense resistor for a 1% error in value will be  $V_\epsilon = -0.42468$  mV, therefore the current in the circuit will be:

$$i_T = \frac{V_\epsilon}{R_s}$$

To support a measurement voltage less the error at the input to the instrument, the input impedance will be defined as:

$$R_M = \frac{V_S - V_\epsilon}{i_T}$$

This translates to the measurement instrument needing an input impedance of  $R_M = 120.0M\Omega$ , which is substantially higher than that of most standard instruments.

The oxygen concentration calculated as a result of the increased input impedance, namely the measured signal, within 1% of the actual generated sensor voltage now yields an oxygen concentration of  $O_2 = 1.03\%$ . For use with standard equipment having an input impedance of  $1M\Omega$ , the lowest operating temperature will be approximately 550-600°C.

## 9.7 Response time with respect to gas changes

Response times to changes in  $O_2$  concentration levels vary according to temperature and gas flow. And importantly the magnitude of change, namely the  $\Delta pO_2$ . Typically, we note that response times are  $0.1 \leq t \leq 0.5$  to within 90% of final stabilised voltage reading for temperatures above 700 °C.

## 9.8 Reducing measurement noise

### Reject DC Common-Mode voltage

Making highly accurate measurements often starts with differential readings. An ideal differential measurement device reads only the potential difference between the positive and negative terminals of its instrumentation amplifier(s). Practical devices, however, are limited in their ability to reject common-mode voltages. Common-mode voltage is the voltage common to both the positive and negative terminals of an instrumentation amplifier.

### Reject AC Common-Mode voltage

Rarely do common-mode voltages consist of only a DC level. Most sources of common-mode voltage contain an AC component in addition to a DC offset. Noise is inevitably coupled onto a measured signal from the surrounding electromagnetic environment. This is particularly troublesome for low-level analogue signals passing through the instrumentation amplifier on a DAQ device.

Sources of AC noise may be broadly classified by their coupling mechanisms – capacitive, inductive, or radiative. Capacitive coupling results from time-varying electric fields, such as those created by nearby relays or other measurement signals. Inductive or magnetically coupled noise results from time-varying magnetic fields, such as those created by nearby machinery or motors. If the electromagnetic field source is far from the measurement circuit, such as with fluorescent lighting, the electric and magnetic field coupling is considered combined electromagnetic or radiative coupling. In all cases, a time-varying common-mode voltage is coupled onto the signal of interest, most often in the range of 50-60 Hz (power-line frequency).

An ideal measurement circuit has a perfectly balanced path to both the positive and negative terminals of an instrumentation amplifier. Such a system would completely reject any AC-coupled noise.

### Break Ground Loops

Ground loops are arguably the most common source of noise in data acquisition systems. Proper grounding is essential for accurate measurements, yet it is a frequently misunderstood concept. A ground loop forms when two connected terminals in a circuit are at different ground potentials. This difference causes a current to flow in the interconnection, which can produce offset errors. Further complicating matters, the voltage potential between signal source ground and DAQ device ground is generally not a DC level. This results in a signal that reveals power-line frequency components in the readings.

## 9.9 Lambda Point for control

The C500 Oxygen Sensor is most sensitive to changes in air/fuel mixture ratios around the lambda point of a given fuel as depicted in the generic sensor response curve given below.

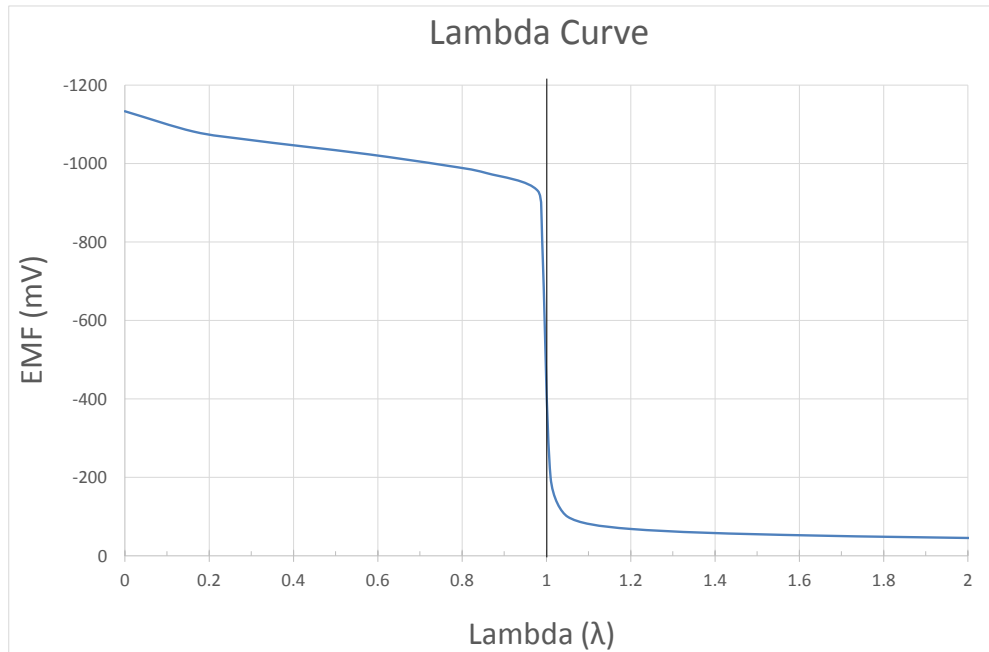

It is important to note that for non-equilibrium reacting systems the sensor coating will partially or fully complete the reaction locally. There are many variables that can influence the extent of this reaction including temperature, mixture ratios, flow rate past the sensor tip, and other reactor design factors. The C500 oxygen sensor is not only well suited to carburising industries and carbon-based equilibrium systems but also responds to changes in  $O_2$  partial pressure for all gas mixtures. The sensor is accurate over a wide range of  $O_2$  partial pressures as given in the Specifications section at the front of this document.

## 10 Ordering information

This sensor can be ordered in a range of different sizes in steps of 100 mm.

**C500-0300**

0300 for 300 mm  
0400 for 400 mm  
...  
1400 for 1400 mm

## 11 Contact information

Ceramic Oxide Fabricators (AUST) Pty Ltd  
83 Wood Street  
California Gully VIC 3556  
Australia

**P** + 61 3 5446 8151  
**F** + 61 3 5446 1215  
**W** [www.cof.com.au](http://www.cof.com.au)  
**E** [ceramics@cof.com.au](mailto:ceramics@cof.com.au)



## 12 Ceramic Oxide Fabricators (AUST) Pty Ltd one (1) year limited warranty

### 12.1 Introduction

This is a limited warranty from Ceramic Oxide Fabricators (AUST) Pty Ltd (as warrantor) that gives you specific legal rights.

You may also have other rights under specific consumer protection laws and regulations – if any (referred to in this warranty as “law”) of the country, state or province in which the Product was purchased (“your jurisdiction”). This warranty is governed by and subject to law and is not intended to and does not exclude, limit or suspend any rights you have under law. Some or all of the limitations or exclusions described below may not apply to you.

For the purposes of this warranty –

*COF* means Ceramic Oxide Fabricators (AUST) Pty Ltd (Australian Business Number 59 007 371 824).

*Product* means any COF – branded hardware product manufactured by or for COF and identified by the COF trademark, trade name, or logo affixed to it.

*You* means the original end-user and retail purchaser of a COF Product.

COF reserves the right to make changes at any time to:

1. Product hardware and software components and specifications; and
2. Terms and conditions governing Product use, service and repair; and
3. COF services.

Such changes are entirely at COF's discretion and may involve modification, upgrade, enhancement, replacement, deletion or abandonment.

### 12.2 Specific Warranty obligations

COF warrants that its Product is free from defects in materials and workmanship under normal use for a period of one (1) year from the date of your purchase (the “*Warranty Period*”).

Subject to law and the conditions set out below, if a Product is defective, COF will decide whether to:

1. Repair the Product at no charge, using new parts or parts that are equivalent to the new in performance or reliability; or
2. Exchange the Product with either a new product or one that is equivalent to new in performance, reliability and functionality; or
3. Refund the purchase price of the product,

provided that your claim is made in accordance with this warranty and is received by COF within the warranty period.

A replacement product or part assumes the remaining warranty of the original Product or ninety (90) days from the date of replacement or repair, whichever provides you with the longer coverage.

When a Product or part of a Product is exchanged, any replacement items become your property and the replaced item becomes COF's property. Parts provided by COF in fulfillment of its warranty obligation must only be used in the Product for which warranty service is claimed.

If COF agrees to refund the purchase price of a Product, the refund can only be paid after you have returned that Product to COF. All returned Products become COF's property.

COF does not make any representation that it will be able to repair or exchange any Product without loss of or corruption to programs and data.

### 12.3 Warranty exclusions and limitations

This limited warranty applied only to COF Products and does not apply to any non-COF hardware product or any software, even if packaged and sold with a COF product. Manufacturers, suppliers, or publishers, other than COF, may provide their own warranties to you, but COF, in so far as permitted by law, provides itself “as is”.

COF Limited Warranty

Software (including system software) and hardware distributed by COF with or without the COF brand name is not covered under this warranty. Refer to the licensing agreement accompanying such software for details of your rights and obligations concerning its use.

COF is not responsible for damage arising from failure to properly follow instructions relating to the Product's use.

This warranty does not apply to:

1. consumable parts, such as batteries, unless damage has occurred due to a defect in materials or workmanship; or
2. cosmetic damage, including but not limited to scratches, dents, and worn material on ports; or
3. damage caused by use with non-COF products; or
4. damage caused by accident, abuse, misuse, or external causes (such as earthquake, fire or flood); or
5. damage caused by operating the product outside the permitted or intended uses described by COF; or
6. damage caused by service (including upgrades and expansions) performed by anyone who is not a representative of COF or a COF authorised service provider; or
7. modifications by someone else other than COF to alter Product functionality or capability without COF's written approval; or
8. any COF Product where its serial number has been removed or defaced.

#### **12.4 Important!**

Opening a hardware Product may cause damage; such damage is not covered by this warranty. Only COF or an authorised service provider should open and perform Product service.

To the extent permitted by law: (1) this warranty and your rights under it are exclusive and are in lieu of any other oral, written, statutory, express or implied warranties, remedies and conditions; and (2) COF disclaims all other warranties, including but not limited to warranties of merchantability and fitness for a particular purpose and warranties against

hidden or latent defects. If COF cannot lawfully disclaim statutory or implied warranties then, to the extent permitted by law, all such warranties will be limited in the duration of the express warranty and to the repair or replacement service or refund as determined by COF in its absolute discretion.

No COF reseller, agent, or employee is authorised to make any amendment, extension, or addition to this warranty.

If any term or condition of this warranty is held to be illegal or unenforceable, the legality of the enforceability of the remaining terms and conditions will not be affected or impaired.

Except as provided in this warranty and to the maximum extent permitted by law, COF is not responsible for direct, special, incidental or consequential damages resulting from any breach of the warranty or condition, or under any clause, category of head of claim, including but not limited to loss of use; loss of revenue; loss of actual or anticipated profits (including loss of profits on contracts); goodwill; loss of reputation; loss of damage to or corruption of data; any or indirect or consequential loss or damage howsoever caused including the replacement of equipment and property, and costs of recovering, programming or reproducing any program or data stored in or used with the COF Product and any failure to maintain the confidentiality of data stored on the COF product.

COF does not authorise use of and reliance on any COF Product in safety critical situations, where the failure of COF Product or its compromised performance or interrupted operation could cause or contribute to personal injury or death ("potentially life threatening situations" or "PLTS"). For the avoidance of doubt out of the arising use or misuse and operation of any of its Products in such circumstances.

COF may be prepared to assist you to undertake a risk management assessment and prepare a protocol for your use of COF Products in the context of the PLTS, but always on the basis that all such use (including misuse) remains entirely at your risk.

It is your responsibility to identify and comply with the law governing your use of the Product applicable in each jurisdiction in which the

Product is to be used.

### **12.5 Obtaining Warranty Service**

Before seeking warranty service, please first refer to COF's online help resources identified in the Product documentation.

If the product is still not functioning properly, you should contact the COF representatives or, if applicable, a COF retail store, distributor or authorised service provider.

COF will determine whether the Product requires service, and if so, COF will advise you how, where and by whom the service will be performed.

It is important that you assist COF to diagnose issues with your Product and that you follow COF's warranty processes.

Service options, parts availability and response times vary according to the place in which service is requested. Please note that service options are subject to review and change by COF at any time and COF may restrict service to be performed in the place at which the Product was originally sold.

Upon receipt of the replacement Product or part, the original Product or part becomes the property of COF and you agree to properly follow instructions, including if required, arranging the return of the original Product or part to COF in a timely manner.

When providing service requiring the return of the original Product or part, COF may require a credit card authorisation as security for the retail price of the replacement Product or part and applicable shipping costs. If you follow COF's instructions, COF will cancel the credit card authorisation, and you will not be charged for the Product or part and shipping costs. If you fail to return the replaced Product or part as instructed, COF will charge your credit card for the authorised amount.

If you seek service in a country that is not the country of original purchase, you must comply with the relevant export requirements and be responsible for the payment of all duties, taxes, levies, fees and other charges including shipping and handling costs.

Where international service is available, COF may repair or exchange defective Products and parts with comparable Products or parts that comply with local law.

COF may require you provide proof of purchase details and or comply with registration or other requirements before providing warranty service,

COF will collect, maintain and use your information in accordance with COF's privacy policy.